

CATEGORY : FLAT-PANEL
FUNCTION : FLAT
RANGE : 50"-80"

MODEL : P5080F
REDUCED DEPTH UNIVERSAL FLAT MOUNT

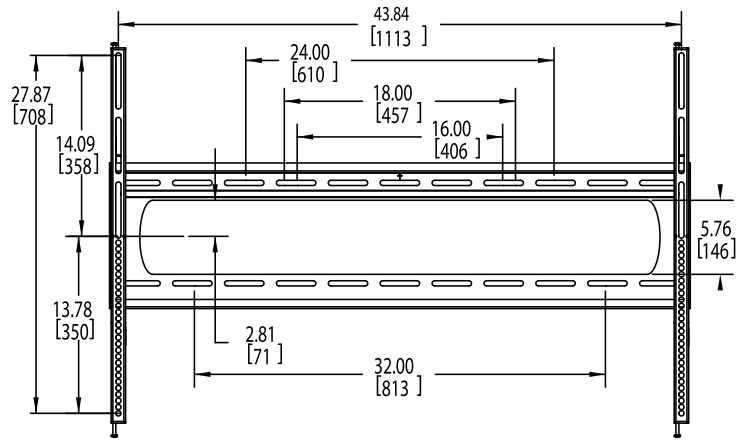
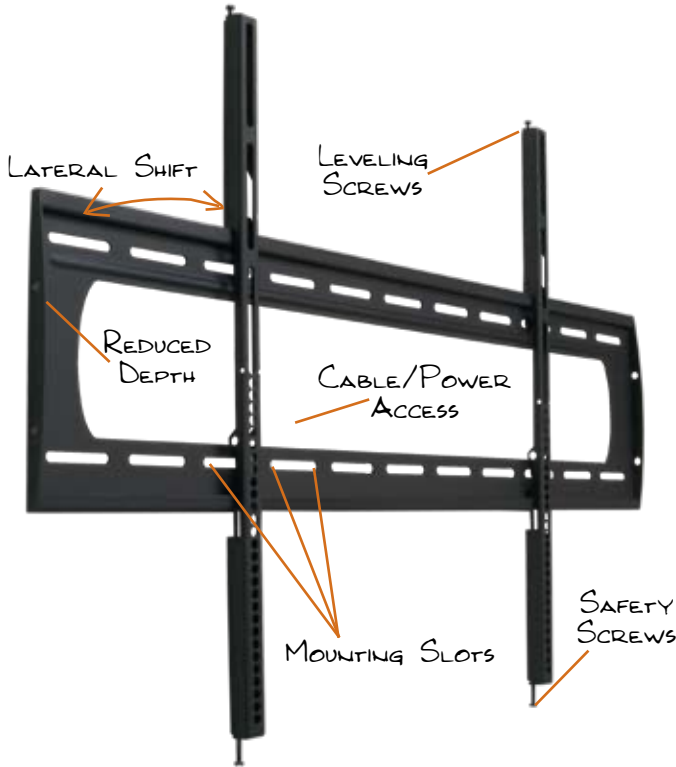

Dimensions in inches and millimeters [mm]
 Drawings subject to change without notice

FEATURES

- Rigid reinforced wall plate design
- 16", 18", 24" and 32" center mounting slots
- Post-mounting display leveling system
- Cable and power box access
- Safety screws prevent flat-panel removal
- Universal hardware pack with patent-pending Universal Spacers
- Includes steel stud, concrete & wood fasteners

SPECIFICATIONS

DISPLAY SIZE	50"-80"
DEPTH FROM WALL	.96" (24mm)
MOUNTING PATTERN	Up to 1110mmx700mm (WxH)
MAX DISPLAY WEIGHT	300 lbs. (136 kgs.)
COLOR	Black

MODELS AND OPTIONAL ACCESSORIES

MODEL	DESCRIPTION	LIST PRICE
P5080F	Black	\$180.00
GB-INWAVP (Optional)	In-Wall AV Power GearBox™	TBD
PCB-CSL1 (Optional)	Cable Lock	\$50.00

RECOMMENDED APPLICATIONS

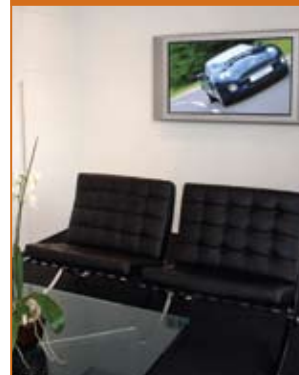

- HOSPITALITY
- HOME
- EDUCATION
- CORPORATE
- RETAIL
- DIGITAL SIGNAGE

